



主要用途

高速开关应用，小型马达驱动，大功率 MOSFET 栅极驱动等。

极限值 ($T_a=25^\circ\text{C}$)

T_{stg}	— 贮存温度	- 55 ~ 150
T_j	— 结温	- 55 ~ 150
V_{DSS}	— 漏极—源极电压	60 V
V_{DGR}	— 漏极—栅极电压 ($R_{GS} = 1M \Omega$)	60V
V_{GS}	— 栅极—源极电压	± 20 V
I_D	— 漏极电流 ($T_c=25^\circ\text{C}$)	500mA
P_D	— 耗散功率 ($T_c=25^\circ\text{C}$)	0.83 W

电参数 ($T_a=25^\circ\text{C}$)

外形图及引脚排列

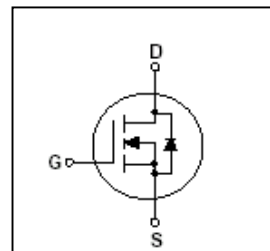
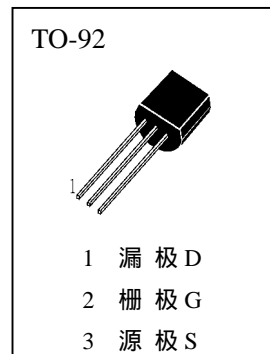

参数符号	符号说明	最小值	典型值	最大值	单位	测试条件
BV_{DSS}	漏—源极击穿电压	60			V	$I_D=100\mu A, V_{GS}=0$
I_{DSS}	零栅压漏极电流			0.5	μA	$V_{DS}=25V, V_{GS}=0$
I_{GSSF}	栅极泄漏电流			10	nA	$V_{GS}=15V, V_{DS}=0$
$V_{GS(th)}$	栅—源极开启电压	0.8		3.0	V	$V_{DS}=V_{GS}, I_D=1mA$
$R_{DS(on)}$	漏—源极导通电阻			5		$V_{GS}=10V, I_D=200mA$
g_{fs}	正向跨导		320		mS	$V_{DS}=10V, I_D=200mA$
C_{iss}	输入电容		24	40	pF	} $V_{DS}=10V, V_{GS}=0,$ $f=1MHz$
C_{oss}	输出电容		17	30	pF	
C_{rss}	反向传输电容		7	10	pF	
$T_{(on)}$	导通延迟时间			10	ns	} $V_{DD}=25V, I_D=200mA,$ $V_{GS}=10V, R_G=25$
$T_{(off)}$	断开延迟时间			10	ns	



典型特性曲线



图 1. 导通特性



图 2. 导通电阻-栅极电压、漏极电流

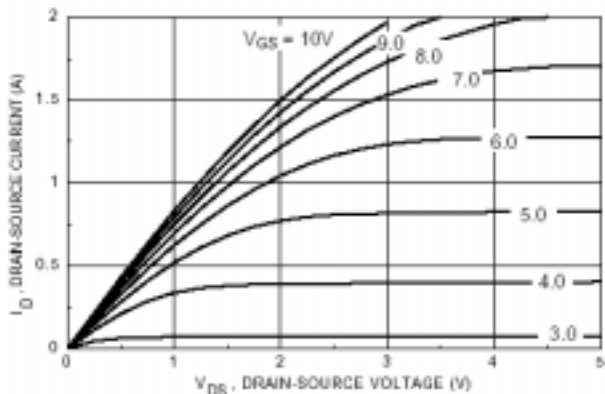

图 3. 导通电阻-结温

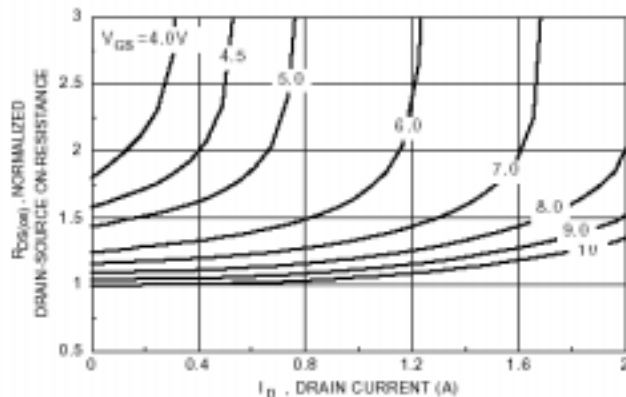

图 4. 导通电阻-漏极电流、结温

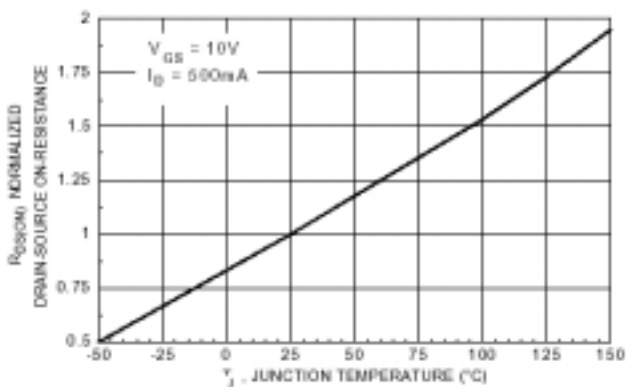

图 5. 转移特性

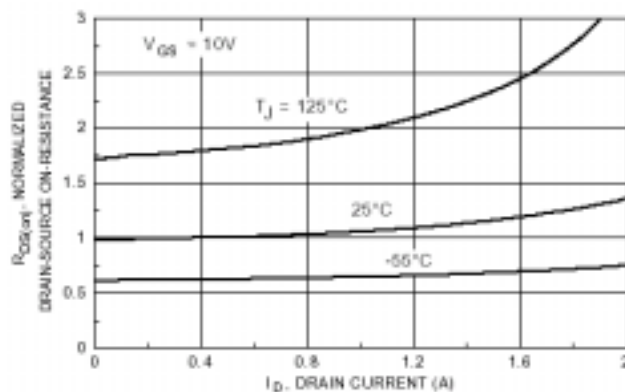

图 6. 栅极开启电压-结温

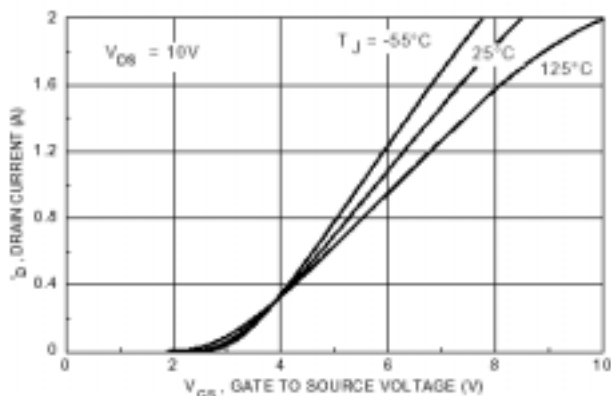

典型特性曲线

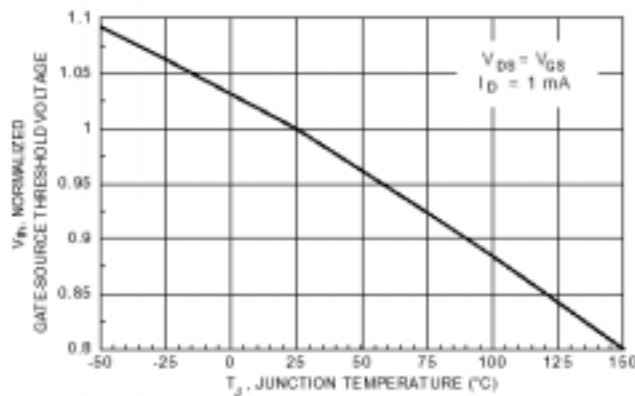

图 7. 击穿电压-结温



图 8. 二极管正向电压-电流、结温

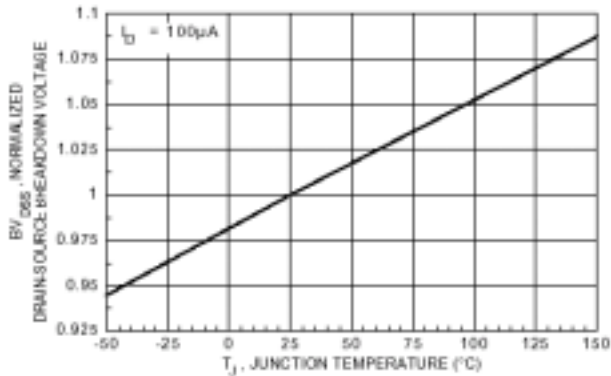

图 9. 电容特性

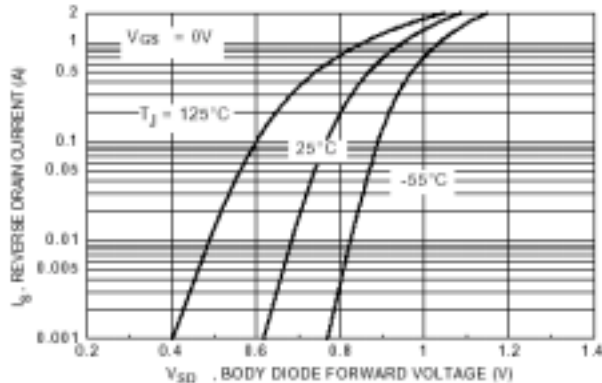

图 10. 栅极电荷特性

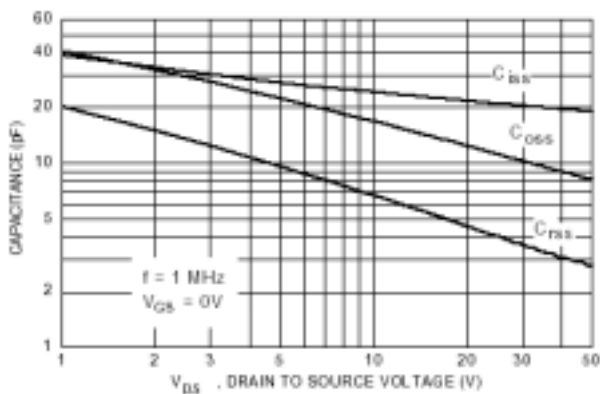

图 11. 开关时间测试电路

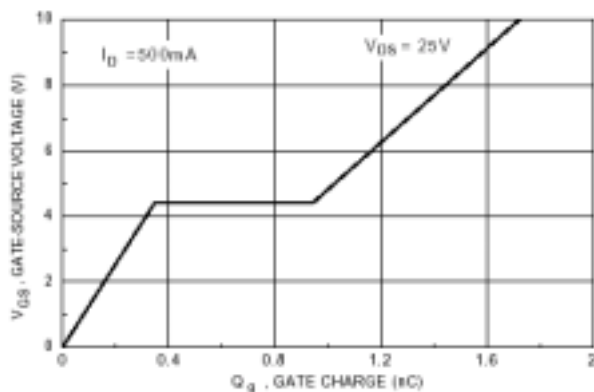

图 12. 开关时间波形

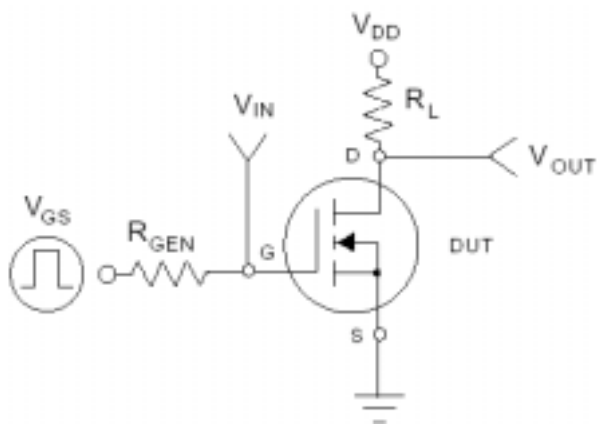

典型特性曲线

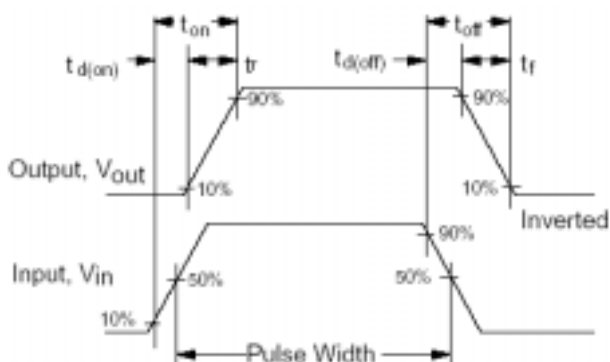
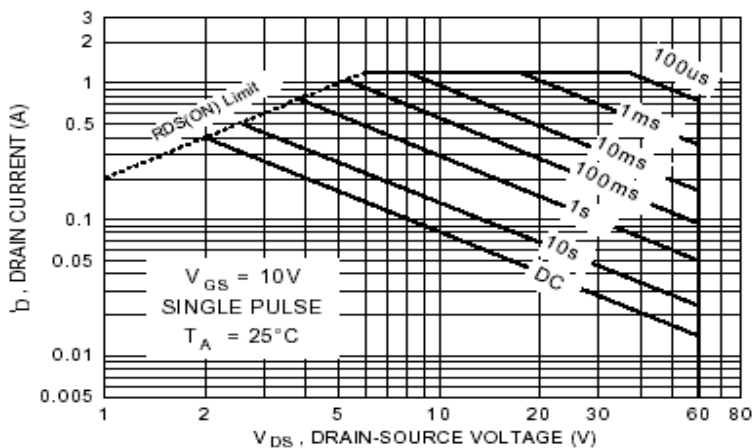

图 13. 最大安全工作区

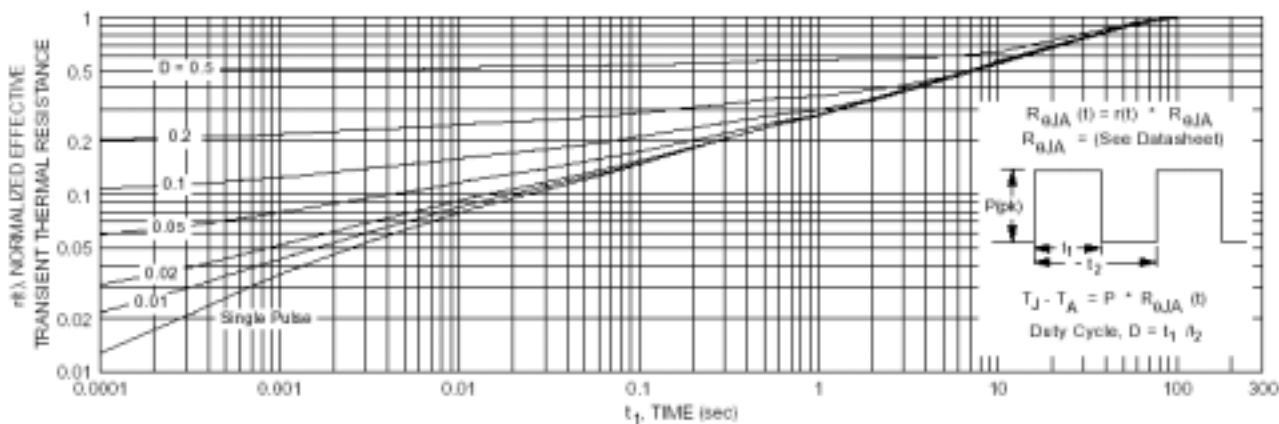

图 14. 瞬态热阻